

PW1115-002

Active GNSS L1/E1/L2/L5/E5 Antenna

Features

- ✓ Size < 1U
- ✓ Omni-directional pattern
- ✓ Integrated LNA and filter with low current consumption
- ✓ Radiation tolerant
- ✓ Stable phase center
- ✓ Wide operating temperature range
- ✓ Designed to NASA GEVS (GSFC-STD-7000)
- ✓ TRL 9

Benefits

- ✓ Commercial off-the-shelf (COTS)
- ✓ Acceptance Tests available
- ✓ Compatible Test Hat available
- ✓ LNA-only version (without radiating element) available for Hardware-In-The-Loop (HITL) tests
- ✓ Qualified for space applications
- ✓ True circular polarization with extremely low Axial Ratio over the entire frequency band
- ✓ Consultation services available (link budget, architecture and system design)

Product Overview

PW1115-002 is a high-performance GNSS L1/E1/L2/L5/E5 antenna designed for harsh space environments. It features excellent axial ratio over the entire frequency band, making it ideal for reliable space vehicle navigation.

This antenna is a perfect choice for LEO, MEO, and GEO missions. Specifically, it is designed to overcome challenges present in the LEO environment over long mission lives, such as Atomic Oxygen, MMOD, etc.

The integrated LNA and filter further improve signal fidelity and make this antenna a perfect choice for applications where interference may be an issue. PW1515-004 is radiation tolerant, lightweight and easy to integrate. It is also available with Test Hats and HITL versions to facilitate testing and integration.

Related Products

Part Number	Description
PW1115-302	GNSS L1/E1/L2/L5/E5 Test Hat
PW1115-202	GNSS L1/E1/L2/L5/E5 LNA
PW1515-004	Active GNSS L1/E1 Antenna

Information furnished by PlaneWave, Inc. is believed to be accurate and reliable. However, no responsibility is assumed by PlaneWave for its use, nor for any infringements of patents or other rights of third parties that may result from its use.



Electrical Specifications

Parameter / Condition	Min	Typ	Max	Unit
Operating Frequency				
L5/E5/L2	1164		1240	MHz
L1/E1	1559		1591	MHz
Polarization		RHCP		
Axial Ratio		2	3	dB
VSWR			2:1	
Passive Gain	2.5	3.5	4	dBic
Pattern Coverage		Omni		
LNA Gain (Notes 1 and 2)	12	15	18	dB
Noise Figure (Note 2)		2.5	3.5	dB
Rejection @ 1650 MHz	50			dBc
Voltage	4.5	5	12	V
Current		75	100	mA

Note 1: LNA gain is customizable upon request

Note 2: Measured over the full operating temperature range

Mechanical Specifications

Parameter / Condition	Value	Unit	Limits
Connector	SMA Female		
Mass	TBD	g	Max
Compatible Test Hat	PW1115-302		

Environmental Specifications

Parameter / Condition	Min	Typ	Max	Unit
LEO Mission Life	5			years
Operating Temperature	-70		100	°C
Humidity (MIL-STD-810 Method 507.6)	65%			
Radiation Hardness (TID)	3			Mrad
Destructive Single Event Effects (Note 1)	37			MeV-cm ² /mg
Vibration	14.1			G _{RMS}

Random Vibration Test Levels
(GSFC-STD-7000)

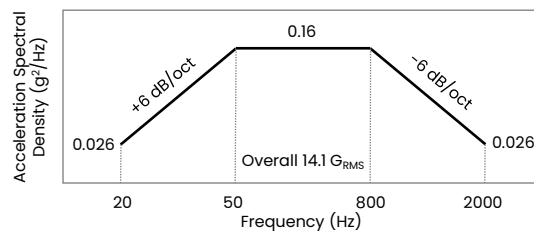

Note 1: No destructive SEE was observed when tested with heavy ions up to the above LET

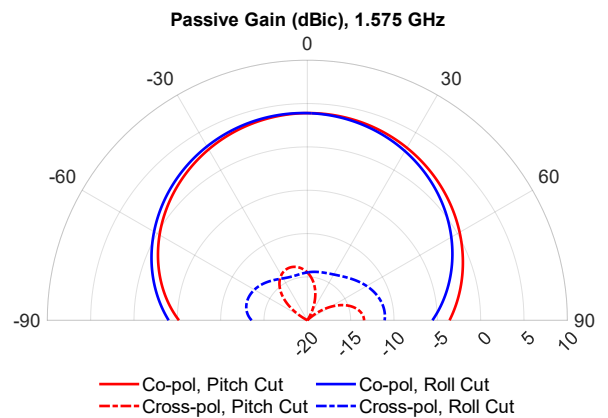
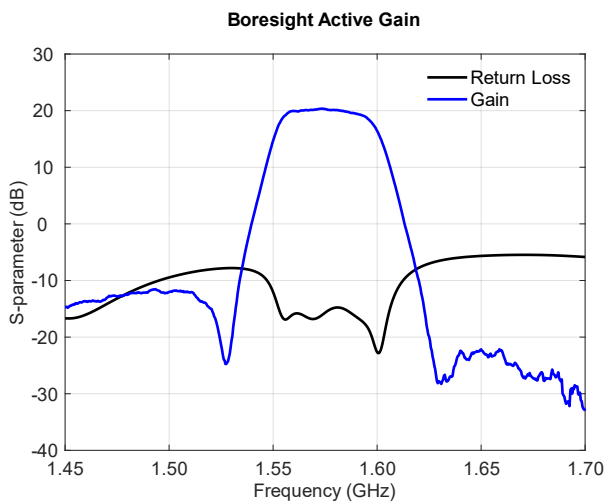
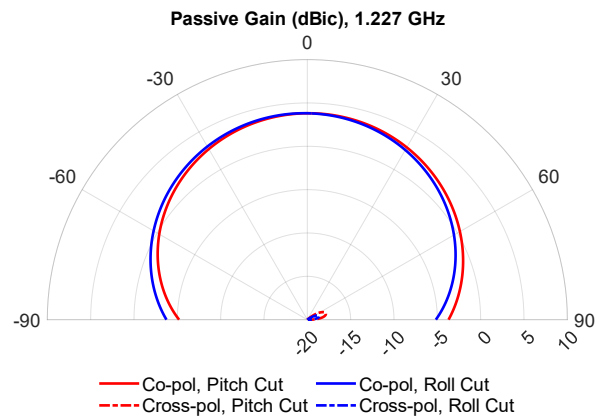
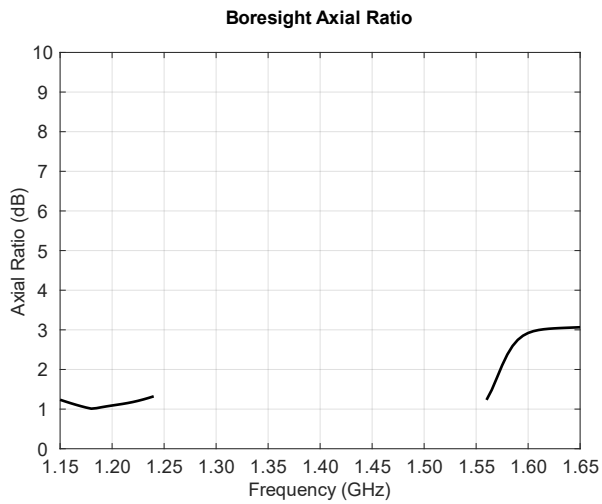
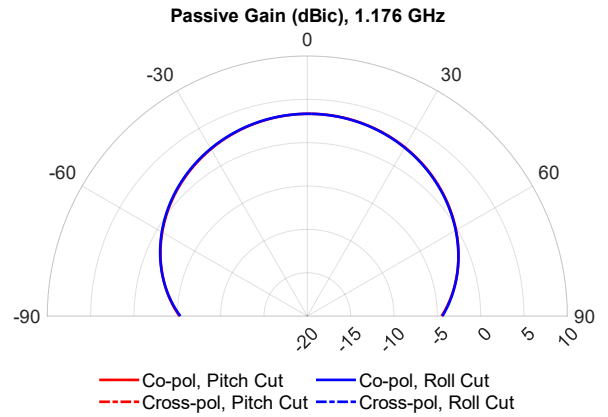
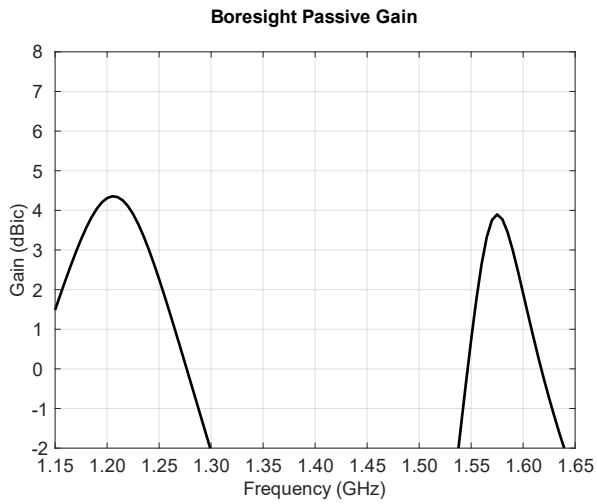

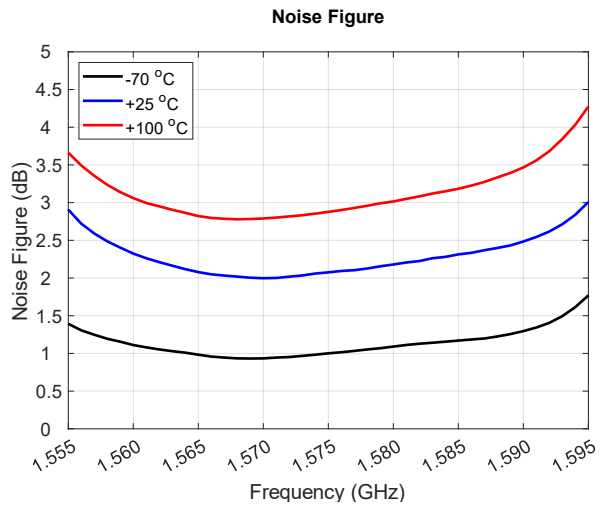
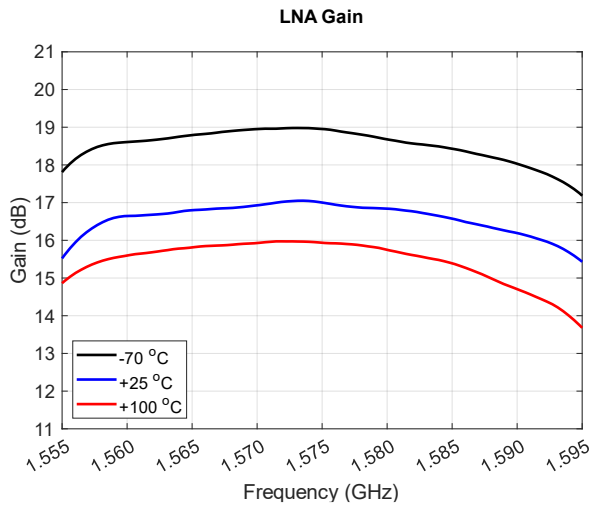

Mechanical Outline

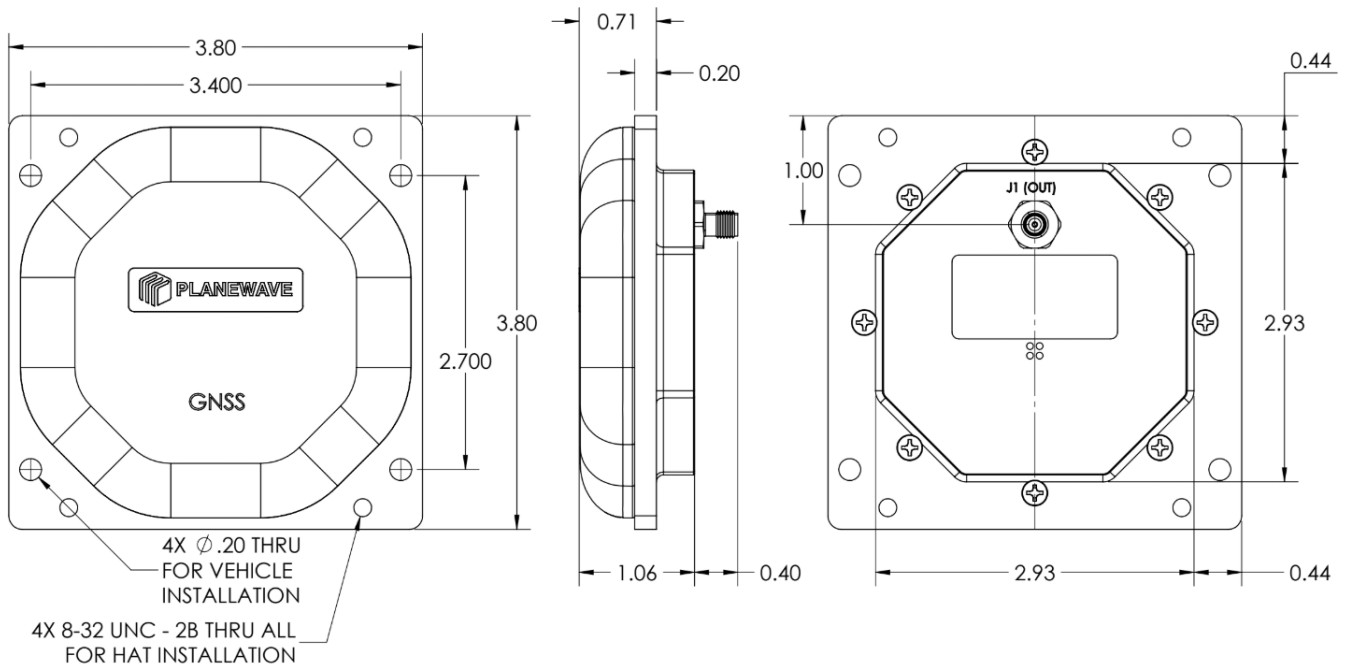

Dimensions shown in inches.

Tolerances - Two Place Decimal: ±0.010, Three Place Decimal: ±0.005

Contact PlaneWave, Inc.

6925 Canby Ave, Ste 110
Reseda, CA 91335

www.planewaveinc.com
sales@planewaveinc.com