

PW2020-310

S-Band Dual-CP RX Omni Test Hat

Features

- ✓ Compact size and lightweight
- ✓ Dual circular polarization: RHCP, LHCP or both
- ✓ Wide operating temperature range

Benefits

- ✓ Commercial off-the-shelf (COTS)
- ✓ Strong and repeatable coupling
- ✓ Easy to mount and dismount
- ✓ Minimal impact on antenna matching
- ✓ No mounting bracket required on the platform
- ✓ RF shielding to protect users and to prevent violation of regulatory limits during testing
- ✓ Consultation services available (link budget, architecture and system design)

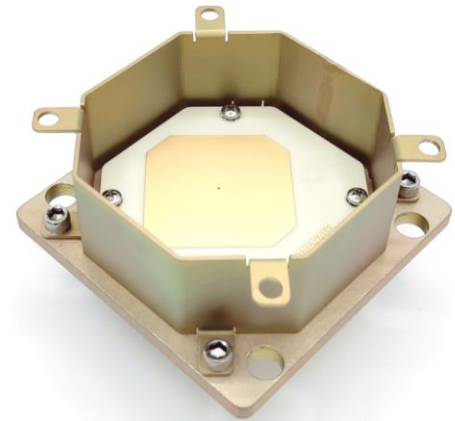

Product Overview

Test Hats serve as the perfect companion for testing the link during integration of PlaneWave antennas on the space platform. All of the PlaneWave's space antennas include Test Hat mounting features which eliminate the need for adding extra brackets on the platform.

PlaneWave Test Hats are compact in size, and without significantly impacting antenna matching, they provide strong coupling to the antenna which enables consistent, accurate and reproducible measurements.

Related Products

Part Number	Description
PW2020-110	S-Band Dual-CP RX Omni Antenna
PW2020-000	Active S-Band RHCP RX Omni Antenna
PW2020-100	S-Band RHCP RX Omni Antenna
PW2222-110	S-Band Dual-CP TX Omni Antenna
PW2222-310	S-Band Dual-CP TX Omni Test Hat
PW1515-001	Active GPS L1 Antenna

Information furnished by PlaneWave, Inc. is believed to be accurate and reliable. However, no responsibility is assumed by PlaneWave for its use, nor for any infringements of patents or other rights of third parties that may result from its use.

Electrical Specifications

Parameter / Condition	Min	Typ	Max	Unit
Operating Frequency	2025		2110	MHz
Polarization		RHCP/LHCP		
VSWR			2.5:1	
Coupling	2.5	3.5	4.5	dB

Mechanical Specifications

Parameter / Condition	Value	Unit	Limits
Connector	SMA Female		
Mass	130	g	Max
Compatible Antenna	PW2020-110		

Environmental Specifications

Parameter / Condition	Min	Typ	Max	Unit
Operating Temperature	-70		100	°C
Storage Temperature	-70		100	°C

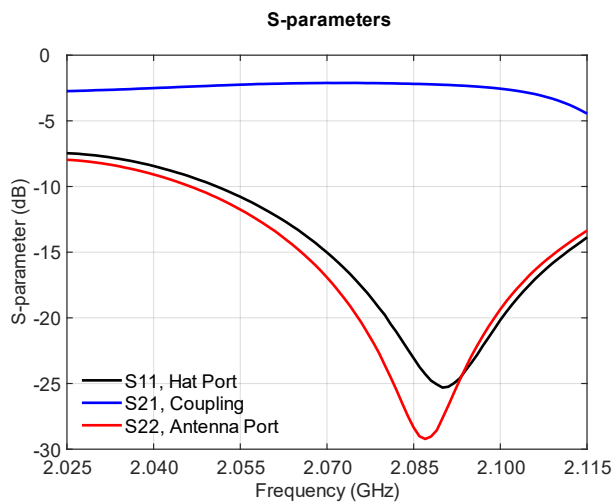

Test Hat + Antenna Assembly, Exploded View



Mechanical Outline

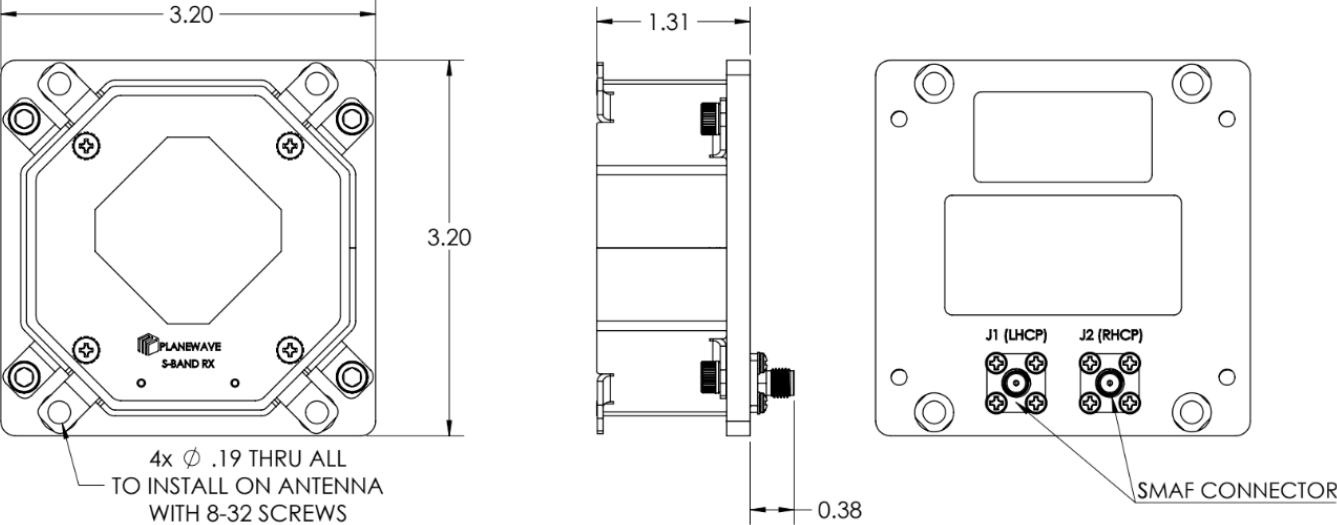

Dimensions shown in inches.
Tolerances - Two Place Decimal: ± 0.010 , Three Place Decimal: ± 0.005

Contact PlaneWave, Inc.

6925 Canby Ave, Ste 110
Reseda, CA 91335

www.planewaveinc.com
sales@planewaveinc.com