

PRELIMINARY



PW2022-302

S-Band RHCP Dual-Port (TX+RX) Omni Test Hat

Features

- ✓ Compact size and lightweight
- ✓ Wide operating temperature range

Benefits

- ✓ Commercial off-the-shelf (COTS)
- ✓ Strong and repeatable coupling
- ✓ Easy to mount and dismount
- ✓ Minimal impact on antenna matching
- ✓ No mounting bracket required on the platform
- ✓ RF shielding to protect users and to prevent violation of regulatory limits during testing
- ✓ Consultation services available (link budget, architecture and system design)

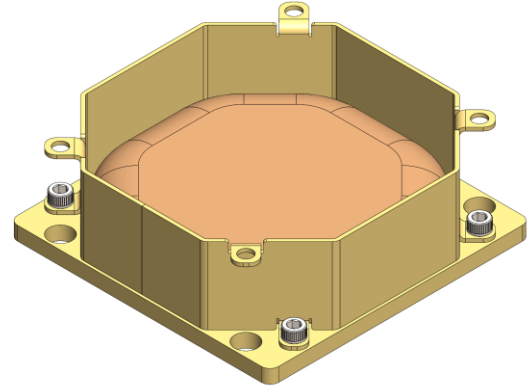

Product Overview

Test Hats serve as the perfect companion for testing the link during integration of PlaneWave antennas on the space platform. All of the PlaneWave's space antennas include Test Hat mounting features which eliminate the need for adding extra brackets on the platform.

PlaneWave Test Hats are compact in size, and without significantly impacting antenna matching, they provide strong coupling to the antenna which enables consistent, accurate and reproducible measurements.

Related Products

Part Number	Description
PW2022-102	S-Band RHCP Dual-Port (TX+RX) Omni Antenna
PW2022-002	Active S-Band RHCP Dual-Port (TX+RX) Omni Antenna
PW2022-101	S-Band RHCP Wideband Omni Antenna
PW2022-111	S-Band Dual-CP Wideband Omni Antenna
PW2020-001	Active S-Band RHCP RX Omni Antenna
PW2222-102	S-Band RHCP TX Omni Antenna
PW1515-004	Active GNSS L1/E1 Antenna

Information furnished by PlaneWave, Inc. is believed to be accurate and reliable. However, no responsibility is assumed by PlaneWave for its use, nor for any infringements of patents or other rights of third parties that may result from its use.

Electrical Specifications

Parameter / Condition	Min	Typ	Max	Unit
Operating Frequency				
TX	2200		2290	MHz
RX	2025		2110	MHz
Polarization	RHCP			
VSWR	2.5:1			
Coupling				
TX	4	5	7	dB
RX	2	3	5	dB

Mechanical Specifications

Parameter / Condition	Value	Unit	Limits
Connector	SMA Female		
Mass	230	g	Max
Compatible Antennas	PW2022-102 & PW2022-002		

Environmental Specifications

Parameter / Condition	Min	Typ	Max	Unit
Operating Temperature	-70		100	°C
Storage Temperature	-70		100	°C

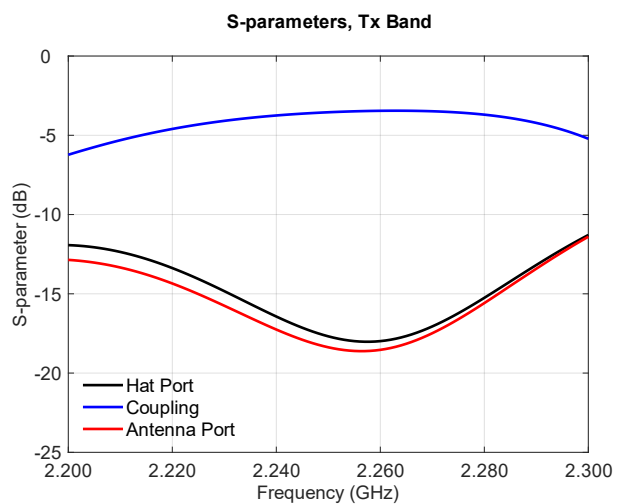
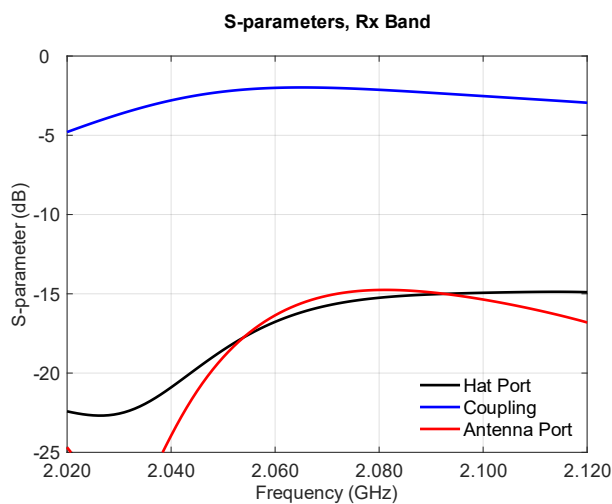

Mechanical Outline

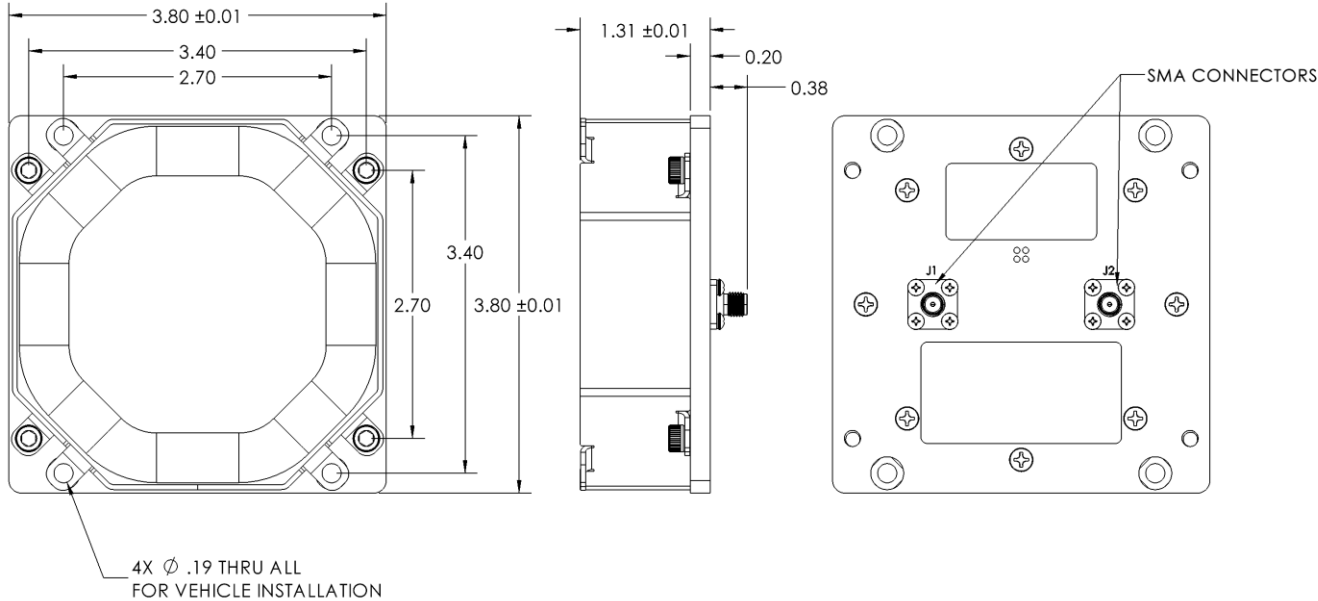

Dimensions shown in inches.

Tolerances - Two Place Decimal: ± 0.010 , Three Place Decimal: ± 0.005

Contact PlaneWave, Inc.

6925 Canby Ave, Ste 110
Reseda, CA 91335

www.planewaveinc.com
sales@planewaveinc.com